



# FANCOIL UNITS

Wall-hung  
Floor standing  
Recessed



# HYDRO IN

Wall and ceiling built-in hydronic fancoil



Ideal for new dwellings.



Renovated  
apartment



New  
buildings



Shop  
office



Public  
administration



Hotel  
Hospital  
Shopping center

## TECHNICAL FEATURES

- **Reduced aesthetic impact**
- **Flow and return connections on the left side** (with possibility of inversion to the right)
- **Respond to every design requirement** (on the wall, ceiling, in false ceiling)
- **Very low sound impact** thanks to the tangential fan and the DC INVERTER motor
- **Flat adapters as standard and 3/4" hydraulic connections**
- **Balancing valves as standard**
- **Availability of numerous accessories**
- **Condensate collection system** for vertical or horizontal installation as standard

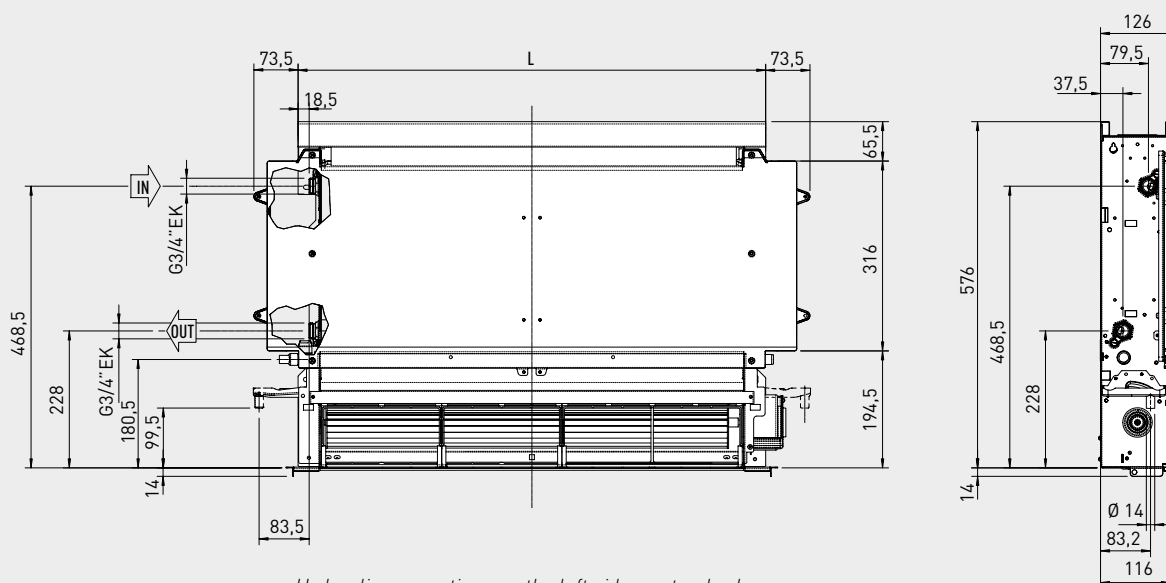

Hydraulic connections on the left side as standard.

Model	L
IN 200	378
IN 400	578
IN 600	778
IN 800	978
IN 1000	1178

Technical data	Unit of measurement	HYDRO IN 200	HYDRO IN 400	HYDRO IN 600	HYDRO IN 800	HYDRO IN 1000
<b>Code</b>		<b>3.029841</b>	<b>3.029842</b>	<b>3.029843</b>	<b>3.029844</b>	<b>3.029845</b>
Weight	kg	17	20	23	26	29
Heating heat output (water at 45/40 °C)	kW	0,97	2,17	3,11	3,88	4,37
Water flow rate (45/40 °C)	l/h	168	374	535	668	752
Heating load losses (water at 45/40 °C)	kPa	7,8	7,2	11,5	21,3	20,4
Heating heat output (water at 70/60 °C)	kW	1,89	3,99	5,47	6,98	8,30
Water flow rate (70/60 °C)	l/h	162	343	471	600	714
Heating load losses (water at 70/60 °C)	kPa	6,7	7,6	16,1	14	19,8
Cooling heat output (water at 7/12 °C)	kW	0,76	1,77	2,89	3,20	3,73
Water flow rate (7/12 °C)	l/h	130	304	497	551	642
Cooling load losses	kPa	4,7	2,9	27,0	24,0	31,0
Power absorbed (Max. / Med. / Min. speed)	W	11/3	19/3	20/4	29/5	30/6
Air flow (Max. / Med. / Min. speed)	m <sup>3</sup> /h	146/90/49	294/210/118	438/318/180	567/410/247	663/479/262
Sound power level at max speed	dB(A)	50	51	53	55	56

*Technical note:*

For the total number of fancoils that can be combined with hybrid systems or heat pumps, it is necessary to evaluate in addition to the power of the appliance, also the flow rate and head characteristics and piping load losses. For more information contact Immergas customer service.



The Immergas compact hybrid systems and the heat pump solutions can all be combined with the range of hydronic fan coils, to offer a complete system.

## HYBRID SYSTEMS

### MAGIS COMBO MAGIS COMBO PLUS

Heat pump and condensing boiler: the combi version, ideal for the replacement, it is suitable for heating systems up to 80 ° C. The heating only version (PLUS) is ideal for new buildings and allows to reach high energy classes by exploiting at maximum the renewable energy

### TRIO V2: PLUS SOLUTION

Compact recessed or in-house system, complete with monobloc AUDAX heat pump and heating only boiler; designed for installations with high DHW comfort requirements. Two or one zone versions are available

### TRIO V2: COMBI SOLUTION

Compact recessed or in-house system, complete with monobloc AUDAX heat pump and combi boiler; recommended for new housing units up to three-room apartments. Two or one zone versions are available

### MAGIS HERCULES ErP

Floor standing condensing boiler with 220 litres combined storage tank and solar circuit integrated, pre-arranged for connection to monoblock AUDAX heat pump, ideal for single-family and small houses

### MAGIS VICTRIX ErP

Wall-hung condensing combi boiler prearranged for connection to AUDAX heat pump, ideal for new apartments and for replacing boilers in existing plants to guarantee high hydraulic performance without set up external manifolds and pumps



MAGIS PRO ErP

AUDAX + RAPAX V2

TRIO V2  
BASE AND PRO SOLUTIONS

## HEAT PUMPS

### MAGIS PRO ErP

Ideal for new residential buildings with very high energy classes, particularly suitable for cold climate areas

### TRIO V2: BASE SOLUTION

Compact recessed or in-house system, complete with monobloc AUDAX heat pump; particularly suitable for temperate climate areas. Two or one zone versions are available

### TRIO V2: PRO SOLUTION



Compact recessed or in-house system, complete with splitted MAGIS PRO ErP heat pump; particularly suitable for cold climate areas. Two or one zone versions are available

### AUDAX + RAPAX V2

Solution that guarantees great comfort in heating and cooling and high sanitary comfort thanks to the water heater with high storage tank capacity; possibility to manage at the same time room cooling and DHW production

## Thermoregulation for HYDRO IN

For the functioning of HYDRO IN it is required to install one of these kits to be able to manage the fan coil.

Tipologia		Codice
<p><b>Smart touch wall controller with temperature probe</b> includes control panel with PI logic and room probe for control up to 30 units. To combine with the on board electronic control with PID full modulating fan code 3.029896. Adjustment of temperature in hot and cold at modulating speed of the engine. It has a 230 V output for control water solenoid valve and presence inlet for deactivation in stand-by mode (for example for window contact or room presence badge hotel).</p> <p><b>Available in two colours: black and white</b></p>		<p>3.029897 <i>(black casing)</i></p> <p>3.029898 <i>(white casing)</i></p>
<p><b>On board electronic control with PID full modulating fan</b> to be provided in combination with the smart touch wall controller with temperature probe code 3.029897 and 3.029898; it is installed inside the fan coil and allows the engine to be operated with continuous modulating operation.</p>		3.029896
<p><b>Universal control board for commercial thermoregulation</b> ideal for installation on the machine, it allows to manage the fan motor with fixed speeds. It has a 230 V output for control of the summer/winter water solenoid valve. It can be combined with commercial thermostats with fan speed selection. The 4 speed inputs activate the fan, according to pre-established speeds (possible also combination of 3-speed thermostats, using 3 of the 4 available inputs); multiple control board can be connected in parallel to a single thermostat.</p>		3.028511
<p><b>Electronic control board with 0-10 V connection</b> It allows to manage the fan motor, with modulating speed. The motor adjustment is carried out through a 0-10 V DC analog input. It has a 230 V output for piloting of the water solenoid valve.</p>		3.028512

## Options for HYDRO IN

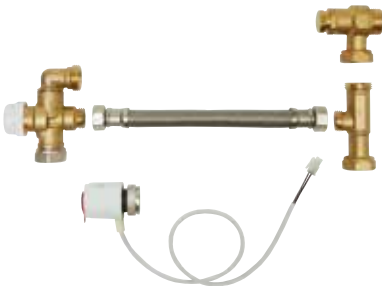
<p><b>2-way group valve kit</b> composed of automatic valve with thermoelectric head and holder to balance the plant load losses. Including insulation.</p>		3.028507
<p><b>3-way group valve kit</b> composed of three-way diverter valve with thermoelectric head, by-pass tube and holder to balance plant load losses. Including insulation.</p>		3.028508
<p><b>Connection cable to shift water connections from left to right</b> to be used in case of reversibility of the hydraulic pipe connections on the right side, rotating the battery 180° (operation to be carried out on site).</p>		3.029834

## Option kits for HYDRO IN

The installation of the HYDRO IN built-in fan coils provides different assembly solutions based on the chosen solution or if installed on the wall, ceiling or false ceiling. The following pages show all the components available based on the chosen solution and the HYDRO IN version.

### Wall built-in installation

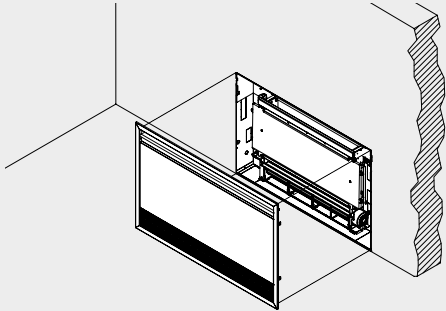
Component	Type
	<p>For this type of installation, in addition to the HYDRO IN, the following optional kits are required:</p> <ul style="list-style-type: none"> <li>• casing</li> <li>• aesthetic cover panel</li> </ul>

### Ceiling built-in installation

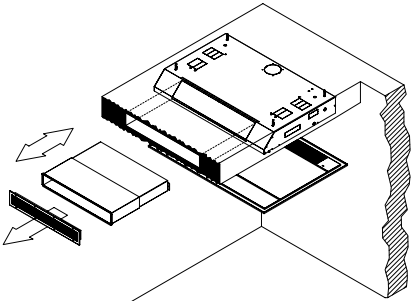
	<p>For this type of installation, in addition to the HYDRO IN, the following optional kits are required:</p> <ul style="list-style-type: none"> <li>• casing</li> <li>• aesthetic cover panel</li> <li>• variable length duct</li> <li>• air flow aluminum grill with straight profile</li> </ul>
--	---

### Recessed installation in false ceiling with bottom air intake and horizontal throwing

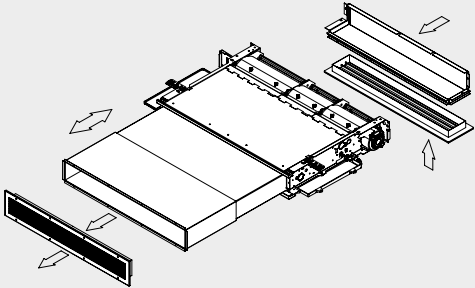
	<p>For this type of installation, in addition to the HYDRO IN, the following optional kits are required:</p> <ul style="list-style-type: none"> <li>• air intake aluminum grill with straight profile</li> <li>• air intake suction duct</li> <li>• variable length duct</li> <li>• air flow aluminum grill with straight profile</li> </ul>
---	--

### Recessed installation in false ceiling with intake and airflow at the bottom

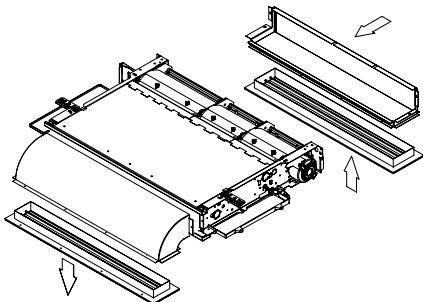
	<p>For this type of installation, in addition to the HYDRO IN, the following optional kits are required:</p> <ul style="list-style-type: none"> <li>• air intake aluminum grill with curved profile</li> <li>• air intake suction duct</li> <li>• 90° bended airflow duct</li> <li>• air flow aluminum grill with curved profile</li> </ul>
---	---

## Kit for wall built-in installation

For this type of installation, in addition to the HYDRO IN, the following optional kits are required:

- Casing
- Aesthetic cover panel

### Sheet metal casing

In zinc-coated metal sheet, designed to be inserted in the walls in which to house HYDRO IN.

Type	Dimensions (H x W x D)		Code
For HYDRO IN 200	725 x 715 x 142 mm		3.029876
For HYDRO IN 400	725 x 915 x 142 mm		3.029877
For HYDRO IN 600	725 x 1115 x 142 mm		3.029878
For HYDRO IN 800	725 x 1315 x 142 mm		3.029879
For HYDRO IN 1000	725 x 1515 x 142 mm		3.029880

### Casing cover panel with intake air grill

RAL 9003 opaque white colour, including air intake grill and adjustable air flow fin.

For HYDRO IN 200	754 x 772 x 9 mm		3.029881
For HYDRO IN 400	754 x 972 x 9 mm		3.029882
For HYDRO IN 600	754 x 1172 x 9 mm		3.029883
For HYDRO IN 800	754 x 1372 x 9 mm		3.029884
For HYDRO IN 1000	754 x 1572 x 9 mm		3.029885

## Kit for ceiling built-in installation

For this type of installation, in addition to the HYDRO IN, the following optional kits are required:

- Casing
- Aesthetic cover panel
- Variable length duct
- Air flow aluminum grill with straight profile

### Sheet metal casing

In zinc-coated metal sheet, designed to be inserted in the ceiling in which to house HYDRO IN.

Type	Dimensions (H x W x D)		Code
For HYDRO IN 200	725 x 715 x 142 mm		3.029876
For HYDRO IN 400	725 x 915 x 142 mm		3.029877
For HYDRO IN 600	725 x 1115 x 142 mm		3.029878
For HYDRO IN 800	725 x 1315 x 142 mm		3.029879
For HYDRO IN 1000	725 x 1515 x 142 mm		3.029880

### Ceiling casing cover panel with accessible air grill

RAL 9003 opaque white colour, including air intake grill.

For HYDRO IN 200	754 x 772 x 9 mm		3.029886
For HYDRO IN 400	754 x 972 x 9 mm		3.029887
For HYDRO IN 600	754 x 1172 x 9 mm		3.029888
For HYDRO IN 800	754 x 1372 x 9 mm		3.029889
For HYDRO IN 1000	754 x 1572 x 9 mm		3.029890

### Variable length air flow duct

Adjustable to adapt to the installation. Made of zinc-coated sheet and internally covered with insulation to avoid condensation.

For HYDRO IN 200		3.029851
For HYDRO IN 400		3.029852
For HYDRO IN 600		3.029853
For HYDRO IN 800		3.029854
For HYDRO IN 1000		3.029855

### Air flow aluminum grill with straight profile

In aluminum with double row of fins for adjusting both horizontal and vertical air flow.

For HYDRO IN 200		3.029861
For HYDRO IN 400		3.029862
For HYDRO IN 600		3.029863
For HYDRO IN 800		3.029864
For HYDRO IN 1000		3.029865

## Kit for recessed installation in false ceiling with bottom air intake and horizontal throwing

For this type of installation, in addition to the HYDRO IN, the following optional kits are required:

- Air intake aluminum grill with straight profile
- Air intake suction duct
- Variable length duct
- Air flow aluminum grill with straight profile

### Air intake aluminum grill with straight profile

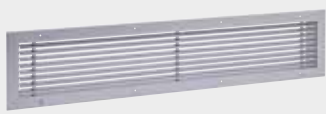
Type		Code
For HYDRO IN 200		3.029866
For HYDRO IN 400		3.029867
For HYDRO IN 600		3.029868
For HYDRO IN 800		3.029869
For HYDRO IN 1000		3.029870

### Air intake suction duct

For HYDRO IN 200		3.029846
For HYDRO IN 400		3.029847
For HYDRO IN 600		3.029848
For HYDRO IN 800		3.029849
For HYDRO IN 1000		3.029850

### Variable length air flow duct

Adjustable to adapt to the installation. Made of zinc-coated sheet and internally covered with insulation to avoid condensation.

For HYDRO IN 200		3.029851
For HYDRO IN 400		3.029852
For HYDRO IN 600		3.029853
For HYDRO IN 800		3.029854
For HYDRO IN 1000		3.029855

### Air flow aluminum grill with straight profile

In aluminum with double row of fins for adjusting both horizontal and vertical air flow.

For HYDRO IN 200		3.029861
For HYDRO IN 400		3.029862
For HYDRO IN 600		3.029863
For HYDRO IN 800		3.029864
For HYDRO IN 1000		3.029865

## Kit for recessed installation in false ceiling with intake and airflow at the bottom

For this type of installation, in addition to the HYDRO IN, the following optional kits are required

- Air intake aluminum grill with curved profile
- Air intake suction duct
- 90° bended airflow duct
- Air flow aluminum grill with curved profile

### Air intake aluminum grill with curved profile

In aluminum. The curved profile completely masks the interior providing more elegance to the application.

Type		Code
For HYDRO IN 200		3.029871
For HYDRO IN 400		3.029872
For HYDRO IN 600		3.029873
For HYDRO IN 800		3.029874
For HYDRO IN 1000		3.029875

### Air intake suction duct

For HYDRO IN 200		3.029846
For HYDRO IN 400		3.029847
For HYDRO IN 600		3.029848
For HYDRO IN 800		3.029849
For HYDRO IN 1000		3.029850

### 90° bended airflow duct

Made of zinc-coated sheet and internally covered with insulation to avoid condensation. It allows to convey the air flow coming from the terminal, towards the nozzle placed at right angles to the air outlet.

For HYDRO IN 200		3.029856
For HYDRO IN 400		3.029857
For HYDRO IN 600		3.029858
For HYDRO IN 800		3.029859
For HYDRO IN 1000		3.029860

### Air flow aluminum grill with curved profile

Made of aluminum. The geometry of the fins is designed to allow a comfortable flow of air.

For HYDRO IN 200		3.029891
For HYDRO IN 400		3.029892
For HYDRO IN 600		3.029893
For HYDRO IN 800		3.029894
For HYDRO IN 1000		3.029895



### App Immergas TOOLBOX



[immergas.com](http://immergas.com)



Immergas S.p.A.  
42041 Brescello (RE) - Italy  
T. 0522.689011  
F. 0522.689178



**IMMERGAS**  
IMMERGAS SPA - ITALY  
CERTIFIED COMPANY  
UNI EN ISO 9001:2015

Design, manufacture and post-sale assistance  
of gas boilers, gas water heaters and related  
accessories